

Swingarm

- Part No. 5720 2.5 m
- Part No. 5721 3.5 m
- Part No. 5722 4.5 m
- Part No. 5723 6 m
- Part No. 5724 8 m

Swingarms are used to increase the working envelope without increasing hose lengths. Optionally, tools can be suspended from the swingarm.

Accessories

Part No. 5740 Linear Suspension Track

The suspension track is installed on the inner link of the swingarm.

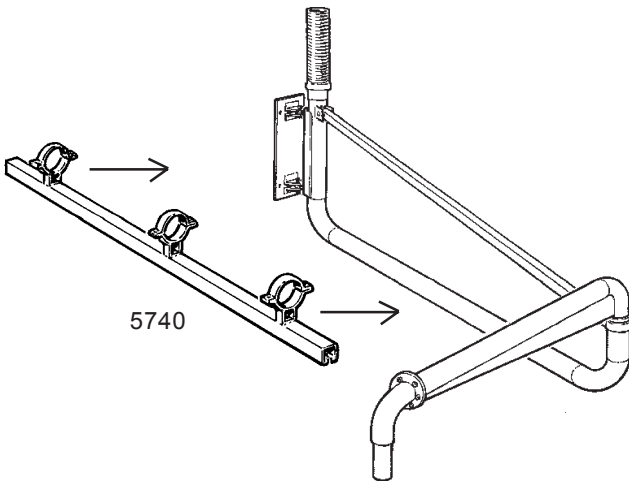

Dimensions

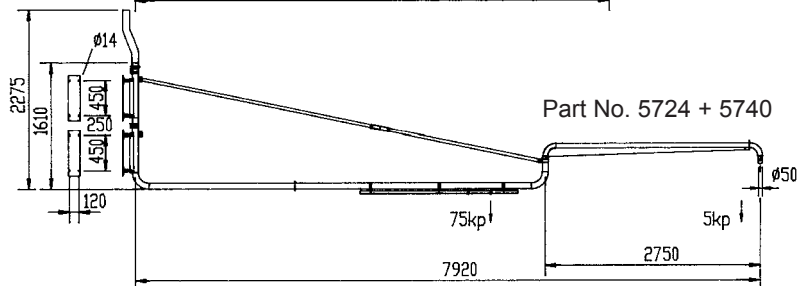
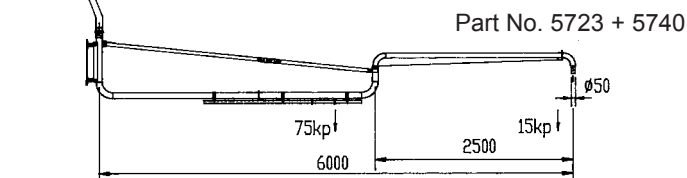
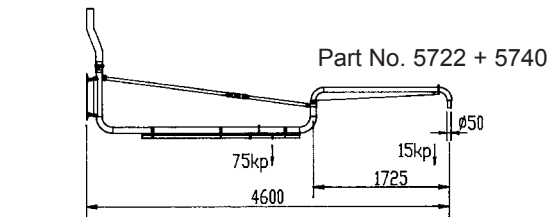
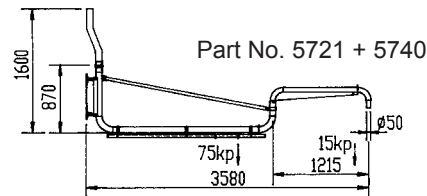
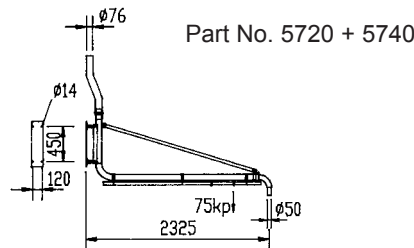

Mounting Alternatives

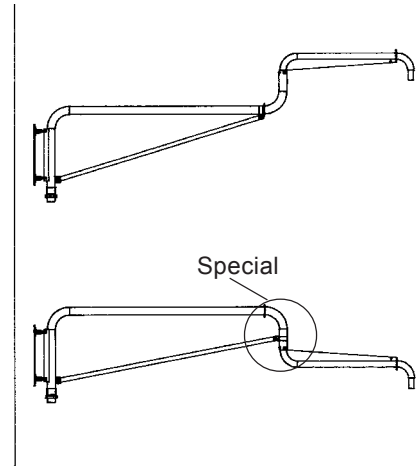

Pressure Loss Swingarm

